



# DATASENSOR

## S50-Px SERIES

### INSTRUCTION MANUAL

## CONTROLS

**OUTPUT LED (S50-Px...A00/B01/C01/C10/C21/E01/F01/T01)**  
The yellow LED ON indicates that the NO output status is closed.

**STABILITY LED (S50-Px...B01/C01/C21/E01/F01)**  
The green LED ON indicates that the received signal has a reserve greater than 30% compared to the output switching value.

**POWER ON LED (S50-Px...G00)**  
The green LED indicates that the sensor is operating.

**TRIMMER (S50-Px...B01/C01/C21/E01/F01/T01)**  
The trimmer can be used to adjust sensitivity; the operating distance increases turning the trimmer clockwise.

**WARNING:** The trimmer rotation is limited to 270° by a mechanical stop. Do not apply excessive torque when adjusting (max 40 Nmm).

## INSTALLATION

The sensor can be fixed by means of the M18x1 threaded body through a  $\varnothing$  18mm hole, using the specific washer and the two CH.24 nuts enclosed (1.5Nm maximum tightening torque).

Alternatively, the sensor can be mounted through the two housing's holes using two screws (M3x22 or longer) and washer. Amongst the various possible solutions, we suggest to choose the combination that offers the best visibility of the signalling LEDs and the easiest access to the trimmer.

Wide range of accessories available: 22mm nuts, h=8mm, (2Nm maximum tightening torque) guarantee an improved torque and various orientable fixing brackets ease the sensor positioning (please refer to the accessories listed in the general catalogue).

The operating distance is measured from the front surface of the sensor lens.

**C/D models:** To improve the detection, the object has to be moved closer or further away from the front surface of the sensor lens.

In case of lateral translation, the object must move as indicated in the figure.



## CONNECTIONS

The connections are compliant to the EN 60947-5-2 standard.

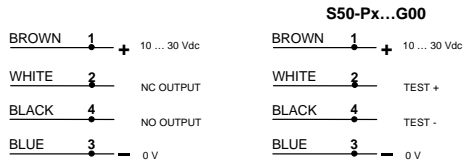

## M12 CONNECTOR

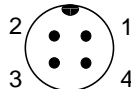

## DIMENSIONS

### AXIAL VERSION

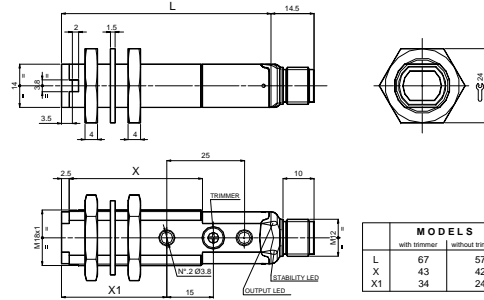

### RADIAL VERSION

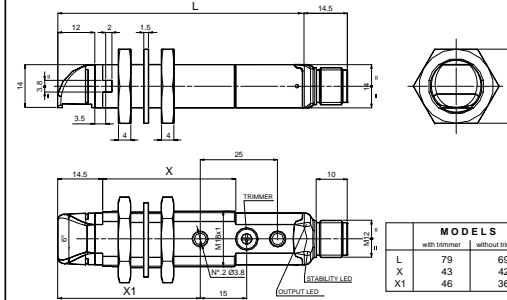

### FIBRE OPTIC VERSION

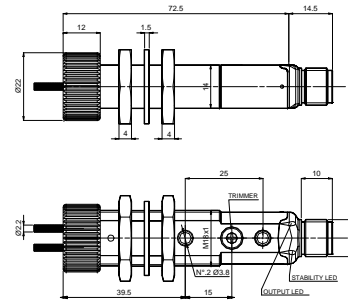

### CABLE VERSION

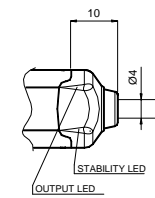

## TECHNICAL DATA

	S50-PA AXIAL VERSION	S50-PR RADIAL VERSION
Power supply:	10 ... 30 Vdc (limit values)	
Ripple:	2 Vpp max.	
Current consumption (output current excluded):	35 mA max.	
Outputs:	NO and NC; PNP or NPN (short-circuit protection)	
Output current:	100 mA max.	
Output saturation voltage:	2 V max.	
Response time:	0.5 ms (2 ms mod.F01/G00)	
Switching frequency:	1KHz (250 Hz mod.F01/G00)	
Indicators:	OUTPUT LED (YELLOW) excluding mod.G00 STABILITY LED (GREEN) (mod.B01/C01/C21/E01/F01) POWER ON LED (GREEN) (mod.G00)	
Setting:	sensitivity trimmer (mod.B01/C01/C21/E01/F01/T01)	
Operating temperature:	-25 ... 55 °C	
Storage temperature:	-25 ... 70 °C	
Insulating strength:	500 Vac 1 min., between electronics and housing	
Insulating resistance:	>20 M $\Omega$ 500 Vdc, between electronics and housing	
Operating distance (typical values):	A00: 0.1...4m on R2 B01: 0.1...3.5m on R2 C01: 0...60cm C10: 0...10cm C21: 0...35cm D00: 0.5...10cm F01/G00: 0...25m E01: 30mm with OF-42 / 100mm with OF-43 T01: 0.1...1m on R2	B01: 0.1...2m on R2 C01: 0...35cm C10: 0...8cm D00: 0...8cm F01/G00: 0...20m T01: 0.1...1m on R2
Emission type:	red (630 nm) (mod.D00/E01) / red (660 nm) (mod.B01/T01) / infrared (880nm) (mod.A00/C01/C10/C21/G00)	
Ambient light rejection:	according to EN 60947-5-2	
Vibrations:	0.5 mm amplitude, 10 ... 55 Hz frequency, for every axis (EN60068-2-6)	
Shock resistance:	11 ms (30 G) 6 shock for every axis (EN60068-2-27)	
Housing material:	PBT	
Lens material:	PMMA	
Mechanical protection:	IP67	
Connections:	2 m cable $\varnothing$ 4 mm / M12 - 4 pole connector	
Weight:	75 g. max. cable vers. / 25 g. max. connector vers.	

## SETTING

### Setting of S50-Px...A00

Position the sensor and reflector on opposite sides. Find the points where the yellow LED (OUT) is switched ON and OFF in both vertical and horizontal positions, and fix the sensor in the centre between these points.

### Setting of S50-Px...B01/T01

Position the sensor and reflector on opposite sides. Turn the sensitivity trimmer to the maximum position. Moving the sensor both vertically and horizontally, determine the power on and off points of the yellow LED (OUT) and then mount the sensor in the middle of the points defined. Optimum operation is obtained when the green LED (mod.B01) is ON and the yellow LED is OFF.

**B01 models:** If necessary reduce sensitivity in order to detect very small targets. In order to improve alignment, repeat the procedure detailed above whilst progressively reducing the sensitivity.

**T01 model:** Turn the sensitivity trimmer counterclockwise until the yellow LED turns ON (pos.A). Turn slowly the trimmer again clockwise until the yellow LED turns OFF (Operating condition, pos.B).



**Setting of S50-Px...F01/G00/E01 with OF-43 (P/R fibre-optics)**  
Position the sensors (fibre terminals) on opposite sides.

Turn the sensitivity trimmer to maximum: moving the sensor both vertically and horizontally, determine the power on and off points of the yellow LED (OUT) and then mount the sensor in the middle of the points defined. Optimum operation is obtained when the green LED is ON and the yellow LED is OFF (the output function and the relative LEDs are inverted in the E01 model with the OF-43 fibre).

If necessary, reduce sensitivity using the trimmer, in order to detect very small targets. In order to improve alignment, repeat the procedure detailed above whilst progressively reducing the sensitivity.

### Setting of S50-Px...C01/C21/E01 with OF-42 (proximity fibre)

Turn the sensitivity trimmer to minimum: the green LED is ON, the yellow LED is OFF. Position the target to detect in front of the sensor or of the fibre terminals. Turn the sensitivity trimmer clockwise until the yellow LED turns ON (Target detected state, pos.A). Remove the target, the yellow LED turns OFF.

Turn the sensitivity trimmer clockwise until the yellow LED turns ON (Background detected state, pos.B).

The trimmer reaches maximum if the background is not detected. Turn the trimmer to the intermediate position C, between the two positions A and B. The green LED must be ON.

### Setting of S50-Px...C10/D00

The operating distance range of these sensors is factory preset: please consider this feature when positioning.

## TEST FUNCTION (S50-Px...G00)

The TEST+ and TEST- inputs can be used to inhibit the emitter and verify that the system is correctly operating. The receiver output should switch when the test is activated while the beam is uninterrupted. The inputs activating voltage range is 10 ... 30 Vdc.

## DECLARATION OF CONFORMITY

We DATASENSOR S.p.A. declare under our sole responsibility that these products are conform to the 2004/108/CE, 2006/95/CE Directives and successive amendments.



## WARRANTY

DATASENSOR S.p.A. warrants its products to be free from defects. DATASENSOR S.p.A. will repair or replace, free of charge, any product found to be defective during the warranty period of 36 months from the manufacturing date. This warranty does not cover damage or liability deriving from the improper application of DATASENSOR products.



DATASENSOR S.p.A. cares for the environment: 100% recycled paper. DATASENSOR S.p.A. reserves the right to make modifications and improvements without prior notification.

## S50-PL/ML SERIES INSTRUCTION MANUAL



### CONTROLS

#### OUTPUT LED (S50-PL/ML...B01/C01/F01)

The yellow LED ON indicates that the N.O. (normally open) output status is closed.

#### POWER ON LED

The green LED indicates that the sensor is operating.

#### TRIMMER (S50-PL/ML...B01/C01/F01)

The trimmer can be used to adjust sensitivity; the operating distance increases turning the trimmer clockwise.

**WARNING:** The trimmer rotation is limited to 270° by a mechanical stop.

Do not apply excessive torque when adjusting (max 40 Nmm).

### INSTALLATION

**S50-PL:** The sensor can be fixed by means of the M18x1 threaded body through a  $\varnothing$  18 mm hole, using the specific washer and the two CH.24 nuts enclosed (1.5 Nm maximum tightening torque).

Alternatively, the sensor can be mounted through the two housing's holes using two screws (M3x22 or longer) and washer.

Amongst the various possible solutions, we suggest to choose the combination that offers the best visibility of the signalling LEDs and the easiest access to the trimmer.

22 mm nuts, h=8 mm, (2 Nm maximum tightening torque) are available to guarantee an improved torque.

**S50-ML:** The sensor can be fixed by means of the M18x1 threaded body through a  $\varnothing$  18 mm hole, using the specific washer and the two CH.24 nuts enclosed (22 Nm maximum tightening torque).

For both plastic version and metallic version are available various orientable fixing brackets to ease the sensor positioning (please refer to the accessories listed in the general catalogue).

The operating distance is measured from the front surface of the sensor lens.

In case of lateral translation, the object must move as indicated in the figure.



### CONNECTIONS

The connections are compliant to the EN 60947-5-2 standard.

#### S50-PL/ML...B01/C01/F01

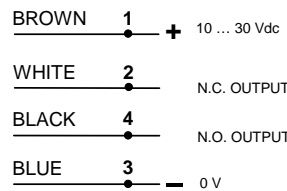

#### S50-PL/ML...G00

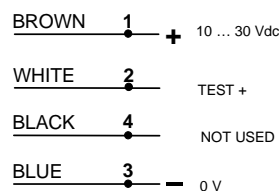

#### M12 CONNECTOR

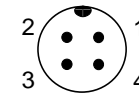

### DIMENSIONS

#### S50-PL VERSIONS

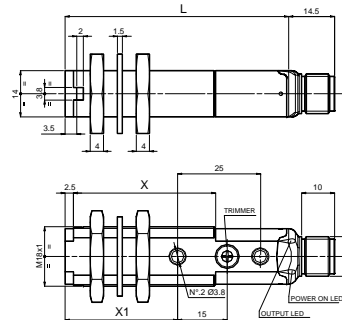

	MODELS	
	B/C/F version	G version
L	67	57
X	43	42
X1	34	24

#### S50-ML VERSIONS

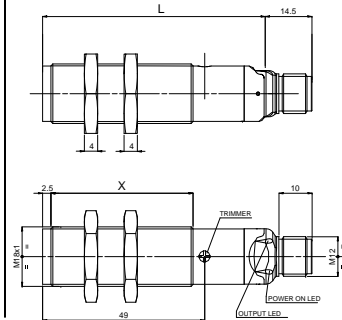

	MODELS	
	B/C/F version	G version
L	67	57
X	43	38

#### CABLE VERSION

#### CABLE VERSION

### TECHNICAL DATA

	S50-PL PLASTIC VERSIONS	S50-ML METALLIC VERSIONS
Power supply:	10 ... 30 Vdc (limit values)	
Ripple:	2 Vpp max.	
Current consumption (output current excluded):	35 mA max. (mod.B01/C01/F01) 30 mA max (mod.G00)	
Outputs:	N.O. and N.C.; PNP or NPN (short-circuit protection)	
Output current:	100 mA max.	
Output saturation voltage:	2 V max.	
Response time:	333 $\mu$ s	
Switching frequency:	1,5 kHz	
Indicators:	OUTPUT LED (YELLOW) (mod.B01/C01/F01) / POWER ON LED (GREEN)	
Setting:	sensitivity trimmer (mod.B01/C01/F01)	
Operating mode:	LIGHT mode on N.O. output / DARK mode on N.C. output (mod.C01) DARK mode on N.O. output / LIGHT mode on N.C. output (mod.B01/F01)	
Operating temperature:	-10 ... 50 °C	
Storage temperature:	-25 ... 70 °C	
Insulating strength:	500 Vac 1 min., between electronics and housing	
Insulating resistance:	>20 M $\Omega$ 500 Vdc, between electronics and housing	
Operating distance (typical values):	B01: 0.1...16 m on R2 C01: 0...35 cm F01/G00: 0...60 m	
Emission type:	RED LASER: Class 1 EN 60825-1 (1994) (mod.B01/C01/G00) Class II CDRH 21 CFR PART 1040.10 (mod.B01/C01/G00) Max. power $\leq$ 1 mW; Pulse = 4.5 $\mu$ S; $\lambda$ = 630...680nm; Frequency = 25 kHz	
Ambient light rejection:	according to EN 60947-5-2	
Vibrations:	0.5 mm amplitude, 10 ... 55 Hz frequency, for every axis (EN60068-2-6)	
Shock resistance:	11 ms (30 G) 6 shock for every axis (EN60068-2-27)	
Housing material:	PBT	Nickel plated brass
Lens material:	PMMA	
Mechanical protection:	IP67	
Connections:	2 m cable $\varnothing$ 4 mm / M12 - 4 pole connector	
Weight:	75 g. max. cable vers./25 g. max. connector vers.	110 g. max. cable vers./60 g. max. connector vers.

### SETTING

#### Setting of S50-PL/ML...B01

Position the sensor and reflector on opposite sides. Turn the sensitivity trimmer to the maximum position.

Moving the sensor both vertically and horizontally, determine the power ON and OFF points of the OUTPUT LED and then mount the sensor in the middle of the points defined.

If necessary reduce sensitivity in order to detect very small targets.

In order to improve alignment, repeat the procedure detailed above whilst progressively reducing the sensitivity.

#### Setting of S50-PL/ML...F01/G00

Position the sensors on opposite sides.

Turn the sensitivity trimmer to maximum: moving the sensor both vertically and horizontally, determine the power ON and OFF points of the OUTPUT LED and then mount the sensor in the middle of the points defined.

If necessary, reduce sensitivity using the trimmer, in order to detect very small targets. In order to improve alignment, repeat the procedure detailed above whilst progressively reducing the sensitivity.

#### Setting of S50-PL/ML...C01

Turn the sensitivity trimmer to minimum: the OUTPUT LED is OFF.

Position the target to detect in front of the sensor.

Turn the sensitivity trimmer clockwise until the OUTPUT LED turns ON (*Target detected state, pos.A*).

Remove the target, the OUTPUT LED turns OFF.

Turn the sensitivity trimmer clockwise until the OUTPUT LED turns ON (*Background detected state, pos.B*).

The trimmer reaches maximum if the background is not detected.

Turn the trimmer to the intermediate position C, between the two positions A and B.



### TEST FUNCTION (S50-PL/ML...G00)

The TEST input can be used to inhibit the emitter and verify that the system is correctly operating.

The receiver output should switch when the test is activated while the beam is uninterrupted.

The input activating voltage range is 10...30 Vdc.

#### DECLARATION OF CONFORMITY

We DATASENSOR S.p.A. declare under our sole responsibility that these products are conform to the 2004/108/CE, 2006/95/CE Directives and successive amendments.



#### WARRANTY

DATASENSOR S.p.A. warrants its products to be free from defects. DATASENSOR S.p.A. will repair or replace, free of charge, any product found to be defective during the warranty period of 36 months from the manufacturing date.

This warranty does not cover damage or liability deriving from the improper application of DATASENSOR products.



DATASENSOR S.p.A. cares for the environment: 100% recycled paper. DATASENSOR S.p.A. reserves the right to make modifications and improvements without prior notification.



## S50-PA/MA...M

Background suppression proximity



## S50-PA/MA...N

Foreground-background suppression proximity

## INSTRUCTION MANUAL

### CONTROLS

#### OUTPUT LED

The yellow LED ON indicates that the N.O. output status is closed.

#### READY/ERROR LED (bicolour)

When the bicoloured LED is continuously green, the sensor is operating in a normal condition and it is ready to function correctly (stability condition).

The red and green blinking of the LED indicates a wrong sensor setting. Please refer to the "SETTING" paragraph to get the correct setting procedure.

#### SET PUSHBUTTON

A long pressure on the pushbutton activates the self-setting procedure.

### INSTALLATION

**S50-PA...M/N:** The sensor can be fixed by means of the M18x1 threaded body through a  $\varnothing$  18 mm hole, using the specific washer and the two CH.24 nuts enclosed (1.5 Nm maximum tightening torque). Alternatively, the sensor can be mounted through the two housing's holes using two screws (M3x22 or longer) and washer. Amongst the various possible solutions, we suggest to choose the combination that offers the best visibility of the signalling LEDs and the easiest access to the SET pushbutton. 22 mm nuts, h=8 mm, (2 Nm maximum tightening torque) are available to guarantee an improved torque.

**S50-MA...M/N:** The sensor can be fixed by means of the M18x1 threaded body through a  $\varnothing$  18 mm hole, using the specific washer and the two CH.24 nuts enclosed (22 Nm maximum tightening torque).

For both plastic version and metallic version are available various orientable fixing brackets to ease the sensor positioning (please refer to the accessories listed in the general catalogue).

The operating distance is measured from the front surface of the sensor lens.

To improve the detection, the object has to be moved closer or further away from the front surface of the sensor lens.

In case of lateral translation, the object must move as indicated in the figure.



### CONNECTIONS

The connections are compliant to the EN 60947-5-2 standard.

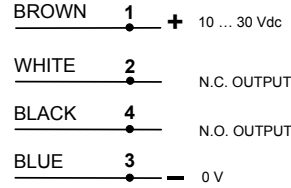

### M12 CONNECTOR

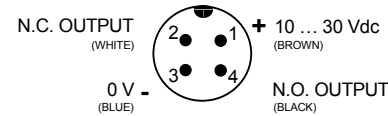

### DIMENSIONS

#### S50-PA VERSIONS

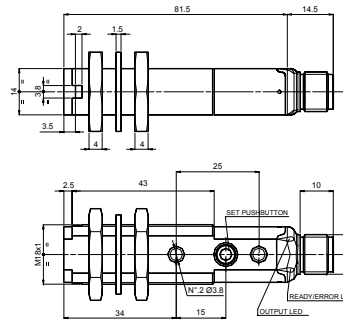

#### S50-MA VERSIONS

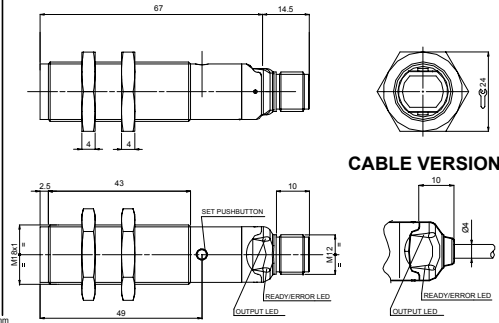

### TECHNICAL DATA

	S50-PA PLASTIC VERSIONS	S50-MA METALLIC VERSIONS
Power supply:	10 ... 30 Vdc (limit values)	
Ripple:	2 Vpp max.	
Current consumption (output current excluded):	30 mA max.	
Outputs:	N.A. and N.C.; PNP or NPN (short-circuit protection)	
Output current:	100 mA max.	
Output saturation voltage:	2 V max.	
Response time:	1 ms mod.M / 2 ms mod.N	
Switching frequency:	500 Hz mod.M / 250 Hz mod.N	
Indicators:	OUTPUT LED (YELLOW) / READY/ERROR LED (GREEN/RED)	
Setting:	SET pushbutton	
Operating mode:	LIGHT mode on N.O. output / DARK mode on N.C. output	
Data retention:	non volatile EEPROM memory	
Operating temperature:	-25 ... 55 °C	
Storage temperature:	-25 ... 70 °C	
Insulating strength:	500 Vac 1 min., between electronics and housing	
Insulating resistance:	>20 M $\Omega$ 500 Vdc, between electronics and housing	
Operating distance (typical values):	background suppression 50...100 mm (mod.M) foreground suppression 40...100 mm and background suppression 45...110mm mod.N)	
Emission type:	RED (630 nm)	
Ambient light rejection:	according to EN 60947-5-2	
Vibrations:	0.5 mm amplitude, 10 ... 55 Hz frequency, for every axis (EN60068-2-6)	
Shock resistance:	11 ms (30 G) 6 shock for every axis (EN60068-2-27)	
Housing material:	PBT	Nickel plated brass
Lens material:	PMMA	
Mechanical protection:	IP67	
Connections:	2 m cable $\varnothing$ 4 mm / M12 - 4 pole connector	
Weight:	75 g. max. cable vers./25 g. max. connector vers.	110 g. max. cable vers./60 g. max. connector vers.

### SETTING

#### EASY TOUCH™

The sensor uses the patent-covered EASY TOUCH™ technology that allows a rapid and safe self-setting of the product.

Two different setting possibilities are available:

- **EASY TOUCH™**; a long pressure of the SET pushbutton allows self-setting.
- **FINE DETECTION**; to be used only in particularly critical conditions; this setting procedure is used only when the EASY TOUCH™ is not sufficient.

#### Setting of S50-PAMA...M

To achieve a correct sensor setting, the background or the object to be suppressed has to be present during self-setting.

- **EASY TOUCH™ (standard detection)**

Place the background or the object to be suppressed inside the operating range.

Press the SET pushbutton until the READY/ERROR LED turns OFF. Release the SET pushbutton and wait for the READY/ERROR LED to turn green.

The sensor is now ready to detect all objects in the set range distinguishing them from the suppressed background (output LED turns ON).

- **Fine detection**

Place the background or the object to be suppressed inside the operating range.

Press the SET pushbutton. The READY/ERROR LED turns OFF. Keep the SET pushbutton pressed until the READY/ERROR LED blinks green.

The sensor performs a fine adjustment and is ready to detect objects also very near the suppressed background (output LED turns ON).

#### Setting of S50-PAMA...N

To achieve a correct sensor setting, the object to be detected has to be used during self-setting.

- **EASY TOUCH™ (standard detection)**

Place the object to be detected in front of the sensor inside the operating range.

Press the SET pushbutton until the READY/ERROR LED turns OFF. Release the SET pushbutton and wait for the READY/ERROR LED to turn green.

The sensor is ready to detect the object (output LED turns ON) excluding the background and foreground range (and thus any object closer to the sensor respect to the reading field).

- **Fine detection**

Place the object to be detected inside the operating range.

Press the SET pushbutton. The READY/ERROR LED turns OFF. Keep the SET pushbutton pressed until the READY/ERROR LED blinks green.

The sensor performs a fine adjustment and is ready to detect with better precision objects (output LED turns ON) at the pre-set operating distance, suppressing the background and foreground, even if the latter is very close to the sensing range.

#### DECLARATION OF CONFORMITY

We DATASENSOR S.p.A. declare under our sole responsibility that these products are conform to the 2004/108 CEE, 73/23 CEE Directives and successive amendments.



#### WARRANTY

DATASENSOR S.p.A. warrants its products to be free from defects. DATASENSOR S.p.A. will repair or replace, free of charge, any product found to be defective during the warranty period of 36 months from the manufacturing date.

This warranty does not cover damage or liability deriving from the improper application of DATASENSOR products.



DATASENSOR S.p.A. cares for the environment: 100% recycled paper. DATASENSOR S.p.A. reserves the right to make modifications and improvements without prior notification.

## S50-PH/MH SERIES INSTRUCTION MANUAL

CLASS 1 EN 60825-1 (1994)  
LASER PRODUCT

### CONNECTIONS

The connections are compliant to the EN 60947-5-2 standard.

#### S50-PH/MH...B01/C01/F01

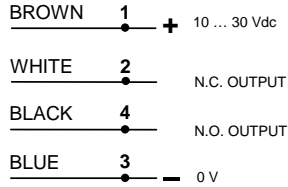

#### S50-PH/MH...G00

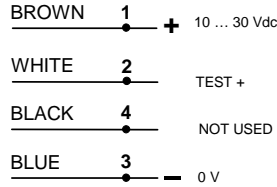

#### M12 CONNECTOR

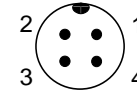

### DIMENSIONS

#### S50-PH VERSION

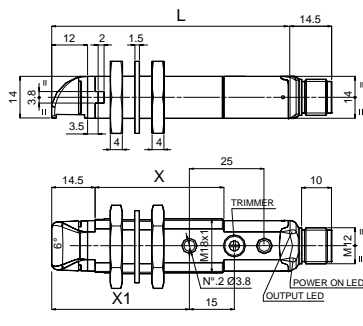

#### S50-MH VERSION

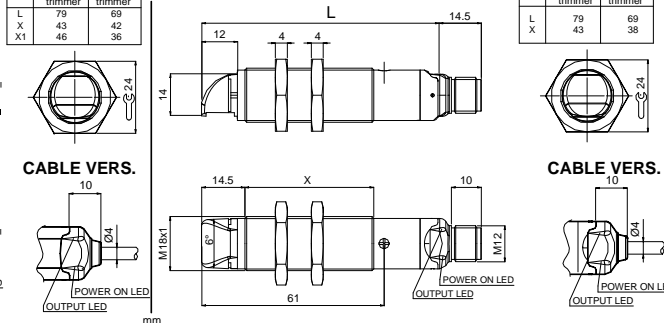

	MODELS	
	with trimmer	without trimmer
L	79	69
X	43	42
	46	36

	MODELS	
	with trimmer	without trimmer
L	79	69
X	43	38

### CONTROLS

#### OUTPUT LED (S50-PH/MH...B01/C01/F01)

The yellow LED ON indicates that the N.O. (normally open) output status is closed.

#### POWER ON LED

The green LED indicates that the sensor is operating.

#### TRIMMER (S50-PH/MH...B01/C01/F01)

The trimmer can be used to adjust sensitivity; the operating distance increases turning the trimmer clockwise.

**WARNING:** The trimmer rotation is limited to 270° by a mechanical stop. Do not apply excessive torque when adjusting (max 40 Nmm).

### INSTALLATION

**S50-PH:** The sensor can be fixed by means of the M18x1 threaded body through a  $\varnothing$  18 mm hole, using the specific washer and the two CH.24 nuts enclosed (1.5 Nm maximum tightening torque). Amongst the various possible solutions, we suggest to choose the combination that offers the best visibility of the signalling LEDs and the easiest access to the trimmer.

22 mm nuts, h=8 mm, (2 Nm maximum tightening torque) are available to guarantee an improved torque.

**S50-MH:** The sensor can be fixed by means of the M18x1 threaded body through a  $\varnothing$  18 mm hole, using the specific washer and the two CH.24 nuts enclosed (22 Nm maximum tightening torque).

Various orientable fixing brackets for both plastic and metallic versions are available to ease sensor positioning (please refer to the accessories listed in the general catalogue).

The operating distance is measured from the front surface of the sensor lens.

### TECHNICAL DATA

	S50-PH PLASTIC VERSIONS	S50-MH METAL VERSIONS
Power supply:	10 ... 30 Vdc limit values	
Ripple:	2 Vpp max.	
Current consumption (output current excluded):	35 mA max. (mod.B01/C01/F01) 30 mA max (mod.G00)	
Outputs:	N.O. and N.C.; PNP or NPN (short-circuit protection)	
Output current:	100 mA max.	
Output saturation voltage:	2 V max.	
Response time:	333 $\mu$ s	
Switching frequency:	1.5 kHz	
Indicators:	OUTPUT LED (YELLOW) (mod.B01/C01/F01) POWER ON LED (GREEN)	
Setting:	sensitivity trimmer (mod.B01/C01/F01)	
Operating mode:	LIGHT mode on N.O. output / DARK mode on N.C. output (mod.C01) DARK mode on N.O. output / LIGHT mode on N.C. output (mod.B01/F01)	
Operating temperature:	-10 ... 50 °C	
Storage temperature:	-25 ... 70 °C	
Insulating strength:	500 Vac 1 min., between electronics and housing	
Insulating resistance:	>20 M $\Omega$ 500 Vdc, between electronics and housing	
Operating distance (typical values):	B01: 0.1...9 m on R2 reflector C01: 0...25 cm F01/G00: 0...50 m	
Emission type:	RED LASER: Class 1 EN 60825-1 (1994) (mod.B01/C01/G00) Class II CDRH 21 CFR PART 1040.10 (mod.B01/C01/G00) Max. power $\leq$ 1 mW; Pulse = 4.5 $\mu$ s; $\lambda$ = 630...680 nm; Frequency =25 kHz	
Ambient light rejection:	According to EN 60947-5-2	
Vibrations:	0.5 mm amplitude, 10 ... 55 Hz frequency, for every axis (EN60068-2-6)	
Shock resistance:	11 ms (30 G) 6 shock for every axis (EN60068-2-27)	
Housing material:	PBT	Nickel-plated brass
Lens material:	PMMA	
Mechanical protection:	IP67	
Connections:	2 m cable $\varnothing$ 4 mm / M12 - 4 pole connector	
Weight:	75 g, max. cable vers. /25 g, max. conn. vers.	110 g, max. cable vers. /60 g, max. conn. vers.

### SETTING

#### Setting of S50-PH/MH...B01

Position the sensor and reflector on opposite sides. Turn the sensitivity trimmer to the maximum position. Moving the sensor both vertically and horizontally, determine the power ON and OFF points of the OUTPUT LED and then mount the sensor in the middle of the points defined.

If necessary reduce sensitivity in order to detect very small targets. In order to improve alignment, repeat the given procedure whilst progressively reducing the sensitivity.

#### Setting of S50-PH/MH...F01/G00

Position the sensor and reflector on opposite sides. Turn the sensitivity trimmer to maximum: moving the sensor both vertically and horizontally, determine the power ON and OFF points of the OUTPUT LED and then mount the sensor in the middle of the points defined.

If necessary, reduce sensitivity using the trimmer, in order to detect very small targets. In order to improve alignment, repeat the procedure detailed above whilst progressively reducing the sensitivity.

#### Setting of S50-PH/MH...C01

Turn the sensitivity trimmer to minimum: the OUTPUT LED is OFF.

Position the target to detect in front of the sensor. Turn the sensitivity trimmer clockwise until the OUTPUT LED turns ON (Target detected state, pos.A).

Remove the target, the OUTPUT LED turns OFF.

Turn the sensitivity trimmer clockwise until the OUTPUT LED turns ON (Background detected state, pos.B).

The trimmer reaches maximum if the background is not detected.

Turn the trimmer to the intermediate position C, between the two positions A and B.



### TEST FUNCTION (S50-PH/MH...G00)

The TEST+ input can be used to deactivate the emitter and verify that the system is operating correctly.

The receiver output should switch when the test is activated while the beam is uninterrupted.

The input activating voltage range is 10...30 Vdc.

#### DECLARATION OF CONFORMITY

We DATASENSOR S.p.A. declare under our sole responsibility that these products are conform to the 2004/108/CE, 2006/95/CE Directives and successive amendments.



#### WARRANTY

DATASENSOR S.p.A. warrants its products to be free from defects. DATASENSOR S.p.A. will repair or replace, free of charge, any product found to be defective during the warranty period of 36 months from the manufacturing date.

This warranty does not cover damage or liability deriving from the improper application of DATASENSOR products.



DATASENSOR S.p.A. cares for the environment: 100% recycled paper. DATASENSOR S.p.A. reserves the right to make modifications and improvements without prior notification.



## S50-PS/MS...M

Background suppression

# INSTRUCTION MANUAL

## CONTROLS

### OUTPUT LED

The yellow LED ON indicates that the NO output is closed.

### READY/ERROR (bicoloured) LED

When permanently green indicates a normal operating conditions and the sensor is ready to function correctly (stability condition). The alternative green / red blinking indicates a wrong detection. Please refer to the "SETTING" paragraph for acquisition or setup procedure indications.

### SET PUSHBUTTON

A long pressure on the pushbutton activates the self-setting procedure.

## INSTALLATION

**S50-PS...M:** The sensor can be fixed by means of the M18x1 threaded body through a  $\varnothing$  18mm hole, using the specific washer and the two CH.24 nuts enclosed (1.5Nm maximum tightening torque).

Alternatively, the sensor can be mounted through the two housing's holes using two screws (M3x22 or longer) and washer.

Amongst the various possible solutions, we suggest to choose the combination that offers the best visibility of the signalling LEDs and the easiest access to the SET pushbutton.

22mm nuts, h=8mm, (2Nm maximum tightening torque) are available to guarantee an improved torque.

**S50-MS...M:** The sensor can be fixed by means of the M18x1 threaded body through a  $\varnothing$  18mm hole, using the specific washer and the two CH.24 nuts enclosed (22Nm maximum tightening torque).

For both plastic version and metallic version are available various orientable fixing brackets to ease the sensor positioning (please refer to the accessories listed in the general catalogue).

The operating distance is measured from the front surface of the sensor lens.

For the best detection, the object has to move closer or further away from this surface. In presence of a lateral movement, the object has to move as indicated in the drawing.

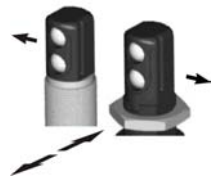

## CONNECTIONS

The connections are compliant to the EN 60947-5-2 standard.

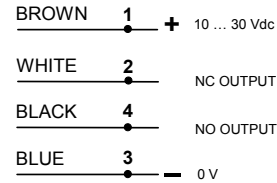

### M12 CONNECTOR

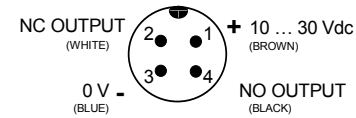

## DIMENSIONS

### S50-PS VERSION

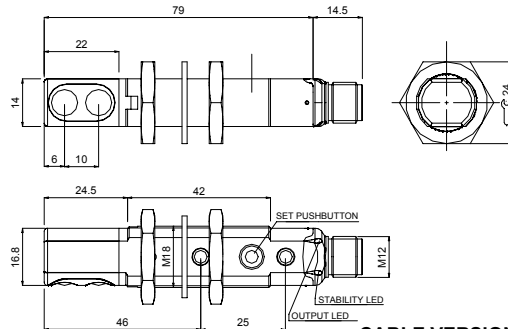

### S50-MS VERSION

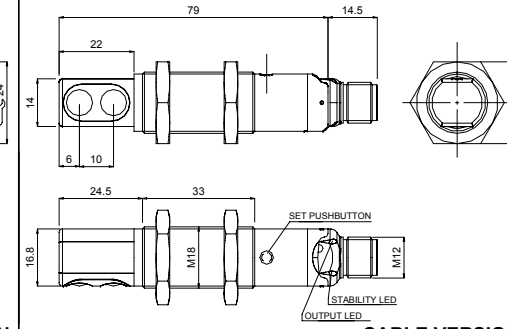

### CABLE VERSION

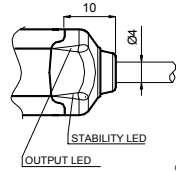

### CABLE VERSION

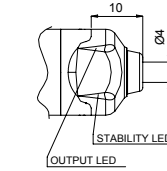

## TECHNICAL DATA

	S50-PS PLASTIC VERSIONS	S50-MS METAL VERSIONS
Power supply:	10 ... 30 Vdc limit values	
Ripple:	2 Vpp max.	
Current consumption (output current excluded):	30 mA max.	
Outputs:	NO and NC; PNP or NPN (short-circuit protection)	
Output current:	100 mA max.	
Output saturation voltage:	2 V max.	
Response time:	1 ms	
Switching frequency:	500 Hz	
Indicators:	OUTPUT LED (YELLOW) / READY/ERROR LED (GREEN/RED)	
Setting:	SET pushbutton	
Operating mode:	LIGHT mode on NO output / DARK mode on NC output	
Data retention:	EEPROM non volatile memory	
Operating temperature:	-25 ... 55 °C	
Storage temperature:	-25 ... 70 °C	
Insulating strength:	500 Vac 1 min., between electronics and housing	
Insulating resistance:	>20 M $\Omega$ 500 Vdc, between electronics and housing	
Operating distance (typical values):	15...100 mm proximity; 50...100 mm background suppression	
Emission type:	red (670 nm)	
Ambient light rejection:	According to EN 60947-5-2	
Vibrations:	0.5 mm amplitude, 10 ... 55 Hz frequency, for every axis (EN60068-2-6)	
Shock resistance:	11 ms (30 G) 6 shock for every axis (EN60068-2-27)	
Housing material:	PBT	Nickel-plated brass
Lens material:	PMMA	
Mechanical protection:	IP67	
Connections:	2 m cable $\varnothing$ 4 mm / M12 - 4 pole connector	
Weight:	90g. max. cable vers. /40g. max. conn. vers.	125g. max. cable vers. /75g. max. conn. vers..

## SETTING

### EASY TOUCH™

The sensor uses the patent-covered EASY TOUCH™ technology that allows a rapid and safe self-setting of the product.

Two different setting possibilities are available:

- **EASY TOUCH™**; press for 2 sec. of the SET pushbutton allows self-setting.
- **FINE DETECTION**; to be used only in particularly critical conditions; this setting procedure is used only when the EASY TOUCH™ is not sufficient.

### Setting of S50-PS/MS...M

To set correctly the sensor, the background or object to be suppressed has to be present during self-setting.

#### - EASY TOUCH™ (standard detection)

Place the background or the object to be suppressed inside the operating range.

Press the SET pushbutton until the READY/ERROR LED turns OFF. Release the SET pushbutton and wait for the READY/ERROR LED to turn green.

The sensor is now ready to detect all objects in the set range distinguishing them from the suppressed background (output LED turns ON).

#### - Fine detection

Place the background or the object to be suppressed inside the operating range.

Press the SET pushbutton and keep it pressed until the READY/ERROR LED turns OFF and then begins to blink green.

The sensor in this case makes a fine setting and is ready to detect with better precision objects different from the background (output LED turns ON).

### DECLARATION OF CONFORMITY

We DATASENSOR S.p.A. declare under our sole responsibility that these products are conform to the 2004/108 CEE, 73/23 CEE Directives and successive amendments.



### WARRANTY

DATASENSOR S.p.A. warrants its products to be free from defects. DATASENSOR S.p.A. will repair or replace, free of charge, any product found to be defective during the warranty period of 36 months from the manufacturing date.

This warranty does not cover damage or liability deriving from the improper application of DATASENSOR products.



DATASENSOR S.p.A. cares for the environment: 100% recycled paper. DATASENSOR S.p.A. reserves the right to make modifications and improvements without prior notification.





## S50-PA/MA...W

Contrast sensor

## INSTRUCTION MANUAL

### CONTROLS

#### OUTPUT LED

The yellow LED on indicates that the N.O. (normally open) output status is closed.

#### READY/ERROR LED (bicolour)

When the bicoloured LED is continuously green, the sensor is operating in a normal condition and it is ready to function correctly (stability condition).

The red and green blinking of the LED indicates a wrong sensor setting. Please refer to the "SETTING" paragraph to get the correct setting procedure.

#### SET PUSHBUTTON

A long pressure on the pushbutton activates the self-setting procedure.

### INSTALLATION

**S50-PA...W:** The sensor can be fixed by means of the M18x1 threaded body through a  $\varnothing$  18 mm hole, using the specific washer and the enclosed 24 mm nuts (maximum torque of tightening 1.5 Nm). Alternatively, the sensor can be mounted through the two housing's holes using two screws (M3x22 or longer) and nuts.

Amongst the various possible solutions, we suggest to choose the combination that offers the best visibility of the signalling Leeds and the easiest access to the SET pushbutton.

22 mm nuts, h=8 mm, (2 Nm maximum tightening torque) are available to guarantee an improved torque.

**S50-MA...W:** The sensor can be fixed by means of the M18x1 threaded body through a  $\varnothing$  18 mm hole, using the specific washer and the two CH.24 nuts enclosed (22 Nm maximum tightening torque).

For both plastic version and metallic version are available various orientable fixing brackets to ease the sensor positioning (please refer to the accessories listed in the general catalogue).

The operating distance is measured from the front surface of the sensor lens.

### CONNECTIONS

The connections are compliant to the EN 60947-5-2 standard.

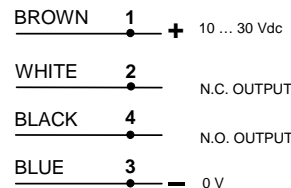

### M12 CONNECTOR

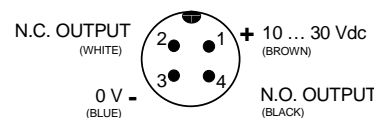

### DIMENSIONS

#### S50-PA VERSIONS

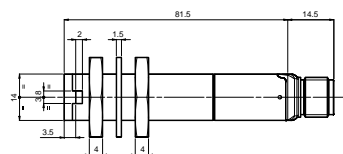

#### CABLE VERSION

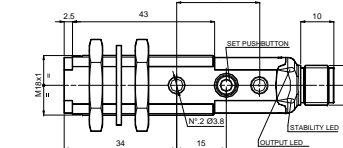

#### S50-MA VERSIONS

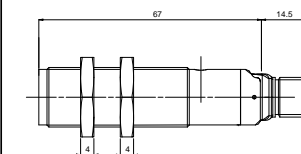

#### CABLE VERSION

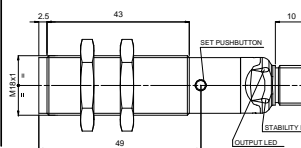

### TECHNICAL DATA

	S50-PA PLASTIC VERSIONS	S50-MA METALLIC VERSIONS
Power supply:	10 ... 30 Vdc (limit values)	
Ripple:	2 Vpp max.	
Current consumption (output current excluded):	25 mA max.	
Outputs:	N.O. and N.C.; PNP or NPN; 30 Vcc max. (short-circuit protection)	
Output current:	100 mA max.	
Output saturation voltage:	2 V max.	
Response time:	100 $\mu$ s	
Switching frequency:	5 kHz	
Indicators:	OUTPUT LED (YELLOW) / LED READY/ERROR (GREEN/RED)	
Setting:	SET pushbutton	
Operating mode:	LIGHT mode on N.O. output / DARK mode on N.C. output	
Data retention:	non volatile EEPROM memory	
Operating temperature:	-10 ... 55 $^{\circ}$ C	
Storage temperature:	-20 ... 70 $^{\circ}$ C	
Insulating strength:	500 Vac 1 min., between electronics and housing	
Insulating resistance:	>20 M $\Omega$ 500 Vdc, between electronics and housing	
Operating distance (typical values):	10 mm $\pm$ 2 mm	
Minimum spot dimension:	4.5 mm	
Emission type:	white light LED (400-700 nm)	
Ambient light rejection:	according to EN 60947-5-2	
Vibrations:	0.5 mm amplitude, 10 ... 55 Hz frequency, for every axis (EN60068-2-6)	
Shock resistance:	11 ms (30 G) 6 shock for every axis (EN60068-2-27)	
Housing:	PBT	Nickel plated brass
Lenses:	PMMA	
Mechanical protection:	IP67	
Connections:	2 m cable $\varnothing$ 4 mm / M12 - 4 pole connector	
Weight:	75 g. max. cable vers. 25 g. max. connector vers.	110 g. max. cable vers. 60 g. max. connector vers.

### SETTING

#### EASY TOUCH™

The sensor uses the patent-covered EASY TOUCH™ technology that allows a rapid and safe self-setting of the product.

Two different setting possibilities are available:

- **EASY TOUCH™**; a long pressure of the SET pushbutton allows self-setting.
- **FINE DETECTION**; to be used only in particularly critical conditions, this setting procedure is used only when the EASY TOUCH™ is not sufficient.

#### Setting of S50-PA/MA...W

To achieve a correct sensor functioning, the coloured mark or object to be detected has to be placed at the right reading distance.

- **EASY TOUCH™ (standard detection in the DARK mode)**

The EASY TOUCH™ technology allows the functioning in the DARK mode (mark presents a lower light intensity respect to the background).

The mark to detect has to be placed correctly at the right reading distance within the sensor spot.

Press the SET pushbutton until the READY/ERROR LED turns OFF. Release the SET pushbutton and wait for the READY/ERROR LED to turn green.

The sensor is now ready to detect the pre-set coloured mark or object (output LED turns ON when the N.O. output is closed).

- **Fine detection (DARK or LIGHT mode)**

This mode offers an improved detection precision.

The sensor can function either in the DARK operating or in the LIGHT operating mode (light-coloured mark ON dark background).

The operating mode is selected automatically by the sensor.

The mark to detect has to be placed correctly at the right reading distance within the sensor spot.

Press the SET pushbutton. The READY/ERROR LED turns OFF. Keep the SET pushbutton pressed until the READY/ERROR LED blinks green. Place the background under the sensor spot.

Press the SET pushbutton again until the READY/ERROR LED turns OFF.

The sensor is now ready to detect, with a very high precision, the pre-set coloured mark (output LED turns ON, READY/ERROR LED turns green).

The output LED is ON and the N.O. output is closed, when the sensor is positioned on the pre-set coloured mark.

#### NOTE

If a setting error will occur please repeat again the EASY TOUCH setting procedure, in order to be sure to restart the setting procedure correctly.

#### DECLARATION OF CONFORMITY

We DATASENSOR S.p.A. declare under our sole responsibility that these products are conform to the 2004/108/CE, 2006/95/CE Directives and successive amendments.



#### WARRANTY

DATASENSOR S.p.A. warrants its products to be free from defects. DATASENSOR S.p.A. will repair or replace, free of charge, any product found to be defective during the warranty period of 36 months from the manufacturing date.

This warranty does not cover damage or liability deriving from the improper application of DATASENSOR products.



DATASENSOR S.p.A. cares for the environment: 100% recycled paper. DATASENSOR S.p.A. reserves the right to make modifications and improvements without prior notification.



## S50-PA/MA...Y

Distance sensor

### INSTRUCTION MANUAL

#### CONTROLS

**OUTPUT LED**  
The yellow LED indicates the analog output status, changing its emission intensity.

**FIELD LED**  
The red LED on indicates that the object to detect is outside the sensor operating field.

#### INSTALLATION

**S50-PA...Y:** The sensor can be fixed by means of the M18x1 threaded body through a single  $\varnothing$  18mm hole, using the specific washer and the enclosed 24mm nuts (maximum couple of tightening 1.5Nm). Alternatively, the sensor can be mounted screwing it through the two housing's holes using two screws (M3x22 or longer) and nuts. Amongst the various possible solutions, we suggest to choose the combination that offers the best visibility of the signaling LED's. 22mm nuts, h=8mm, (2Nm maximum tightening couple) are available to guarantee an improved torque.

**S50-MA...Y:** The sensor can be fixed by means of the M18x1 threaded body through a single  $\varnothing$  18mm hole, using the specific washer and the two CH.24 nuts enclosed (22Nm maximum tightening couple).

For both plastic version and metallic version are available various orientable fixing brackets to ease the sensor positioning (please refer to the accessories listed in the catalogue). The operating distance is measured from the front surface of the sensor lens. In case of lateral translation, the object must move as indicated in the figure.



#### CONNECTIONS

The connections are compliant to the EN 60947-5-2 standard.

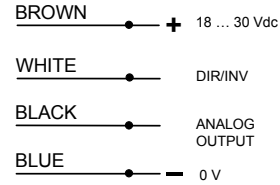

#### M12 CONNECTOR

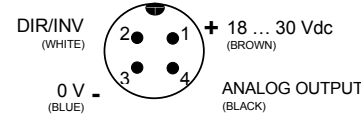

#### DIMENSIONS

##### S50-PA VERSIONS

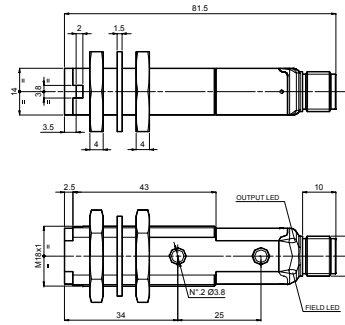

##### CABLE VERSION

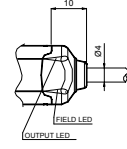

##### S50-MA VERSIONS

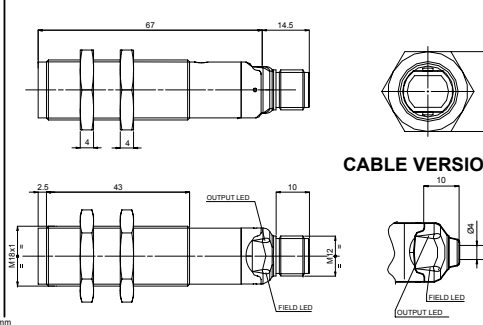

##### CABLE VERSION

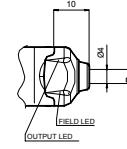

#### TECHNICAL DATA

	S50-PA PLASTIC VERSIONS	S50-MA METALLIC VERSIONS
Power supply:	18 ... 30 Vdc (limit values)	
Ripple:	2 Vpp max.	
Current consumption (output current excluded):	30 mA max.	
Analog output:	0...10V in tension	
Response time:	3.33 ms	
Switching frequency:	150 Hz	
Indicators:	OUTPUT LED (YELLOW) / FILED LED (RED)	
Data retention:	non volatile EEPROM memory	
Operating temperature:	-10 ... 55 °C	
Storage temperature:	-20 ... 70 °C	
Dielectric strength:	500 Vac / 1 min. between electronic parts and housing	
Insulation resistance:	>20 M $\Omega$ / 500 Vdc, between electronic parts and housing	
Operating distance (typical values):	50...100mm	
Emission type:	RED (630nm)	
Ambient light rejection:	According to EN 60947-5-2	
Vibration:	0.5 mm amplitude, 10 ... 55 Hz frequency, for every axis (EN60068-2-6)	
Shock resistance:	11 ms (30 G) 6 shock for every axis (EN60068-2-27)	
Selection:	direct or inverse proportionality of the output respect to the object distance	
Housing:	PBT	Nickel plated brass
Lenses:	PMMA	
Mechanical protection:	IP67	
Connections:	2 m cable $\varnothing$ 4 mm / M12 - 4 pole connector	
Weight:	75g. max. cable vers./25g. max. connector vers.	110g. max. cable vers./60g. max. connector vers.

#### SETTING

No sensor setting is necessary. The user has to select the direct or inverse proportionality of the output respect to the object's distance inside the operating field. This is obtained by means of the DIR/INV input. The direct proportionality is set connecting the DIR/INV input to +Vdc;

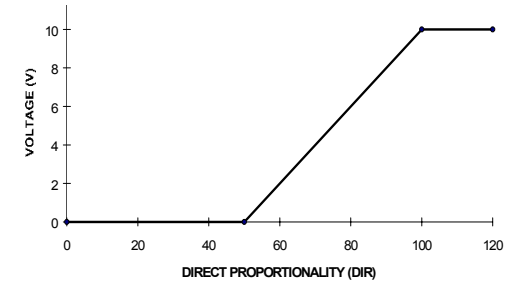

the inverse proportionality is set connecting the DIR/INV input to 0V.

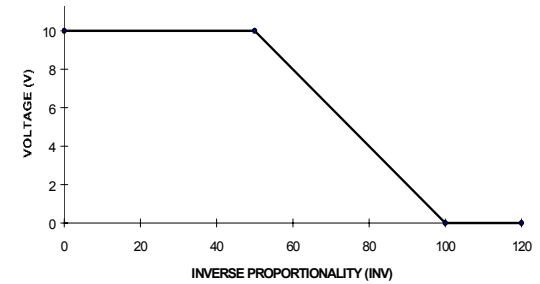

#### DECLARATION OF CONFORMITY

We DATASENSOR S.p.A. declare under our sole responsibility that these products are conform to the 2004/108 CEE, 73/23 CEE Directives and successive amendments.



#### WARRANTY

DATASENSOR S.p.A. warrants its products to be free from defects. DATASENSOR S.p.A. will repair or replace, free of charge, any product found to be defective during the warranty period of 36 months from the manufacturing date. This warranty does not cover damage or liability deriving from the improper application of DATASENSOR products.



DATASENSOR S.p.A. cares for the environment: 100% recycled paper. DATASENSOR S.p.A. reserves the right to make modifications and improvements without prior notification.